

# STEPPING ON

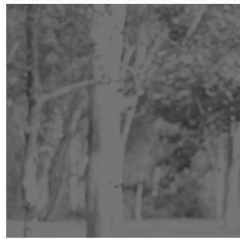

Building Confidence and Reducing Falls in Older Adults

## *Strength and Balance Exercise Manual*



Lindy Clemson | Megan Swann | Jane Mahoney

3rd North American edition

# BALANCE AND STRENGTH EXERCISES TO PREVENT FALLS

## WELCOME TO THE PROGRAM!

These exercises have been selected to help you reduce the chance of falls. When you do these exercises you can improve:

- **Balance**
- **Muscle strength**

You need to do **BALANCE** exercises **daily** and the **STRENGTH** exercises **three times each week**.

## Style Points:

---

- Good form is important with every exercise. Your class leader and therapist will help you learn the positions and movements recommended for each exercise.

---

- Good form means:
  - Using the muscles the exercise is supposed to use.
  - Doing the exercise safely and decreasing the risk of pain.

---

- Looking straight ahead helps promote good posture with the standing and walking exercises.

---



- 
- Good sitting, standing, and walking postures when doing the exercises help support the body for good balance.
- 
- Use slow and steady movements.
- 
- Don't hold your breath! Holding your breath while straining can cause changes in your blood pressure. Breathe normally with each exercise. Generally, exhale during exertion (hardest part of the exercise) and inhale during relaxation.
- 
- Listen to your body and do what feels right for you.
    - You will have days when you can do more and days when you need to do less — this is okay.
    - Everyone has their own pace.
    - It's okay to rest in between repetitions or different exercises.
    - You can “snack” on the exercises at different times of the day.
- 



## Advancing the Exercises:

The exercises need to keep changing so you can keep improving your balance and strength. By making the exercises challenging, you will continue to benefit.

As your balance and strength improves, the exercises will become easier. Once an exercise becomes too easy, go to the next page. Each exercise has a page following it, called “Too Easy?” — this gives suggestions on how to make the exercise more challenging.

- 
- Balance exercises can be made more challenging if you:
    - Increase the number of times you do each exercise.
    - Decrease the amount of support you get from your hands.
    - Hold the position longer.
    - Change your foot placement or the type of step you take so that you keep challenging your balance.
- 
- Strength exercises can be made more challenging if you:
    - First, increase the number of repetitions to the target number for each exercise.
    - Second, when you feel that the repetitions at the target number are too easy, add ankle weights.
    - Again gradually increase the number of repetitions with the ankle weight on. When this is easy, add more weight.
    - Keep repeating this cycle of increasing repetitions with the new weight until it is too easy, then increase the weight again.



## Safety

Challenge your balance safely! Never do standing exercises holding onto an object that may move, such as a chair. Always hold onto something stable, like a counter or solid table. If you use a cane or walker, keep it within reach and start the standing exercises holding the counter or table with both hands. When you do the exercises without holding on, stay near the counter or table so you can touch it when needed. If you are having difficulty letting go, you should keep holding on. It is also okay to take a step to recover your balance in addition to holding on.

You may feel a bit stiff at first. This is quite normal and happens because you are using muscles that are not used to working in this way. It is important you keep exercising. The stiffness will leave as your body becomes more used to the exercises.

If you are very sore the day after exercising, the intensity of the exercise needs to be decreased. Discuss this with your program leader.

You shouldn't feel joint pain with the exercises. The saying "no pain, no gain" is not true. If you have any questions or experience any joint pain, please ask next week or call your program leader to discuss your discomfort.

---

**Make sure you are medically able to do the exercises.**

---

**Exercises should be postponed if you are ill or have a new injury.**

---

**Contact your doctor if, while exercising, you experience:**

- Dizziness
- Chest pain or pressure
- Shortness of breath (you are unable to speak because you are short of breath)
- Nausea



## IMPROVING BALANCE TO PREVENT FALLS

### Balance Exercises:

#### Do these daily

1. Sit-to-stand
2. Sideways walking
3. Heel-toe (tandem) standing
4. Heel-toe (tandem) walking

**Balance is important for everyday activities.** The following quick balance exercises should be done every day. You can do them all at one time or whenever you think about them.

#### **You can improve your balance and maintain the gains.**

For balance exercises, many people need to start with holding on, and that's okay. Gradually, you will hold on less and less. You can challenge your balance safely (for example, by just barely holding on) once you feel the exercise is "too easy" as it is.



## Sit-to-stand balance exercise

### START WITH:

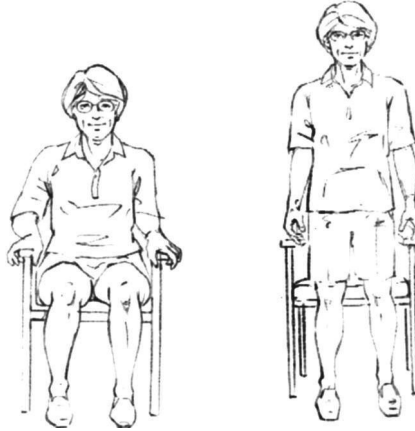

- 1 You could do this exercise while you watch TV.
- 2 Sit on a chair that is not too low.
- 3 Scoot to the edge of the chair so there is space between the back of your knees and the chair.
- 4 Place your feet shoulder-width apart and tuck them under your knees
- 5 Lean forward over your knees (nose over toes).
- 6 Push off **with both hands** using the armrests and stand up slowly.
- 7 Hold for 5 seconds.
- 8 Feel the chair touch the back of your legs so you know you are close enough to the chair before you sit back down.
- 9 Bend forward at your waist and reach behind you for the armrests.
- 10 Slowly sit back down; don't "plop."
- 11 Repeat this exercise 5 times.

**DAILY**



## Sit-to-stand

TOO EASY? THEN TRY:

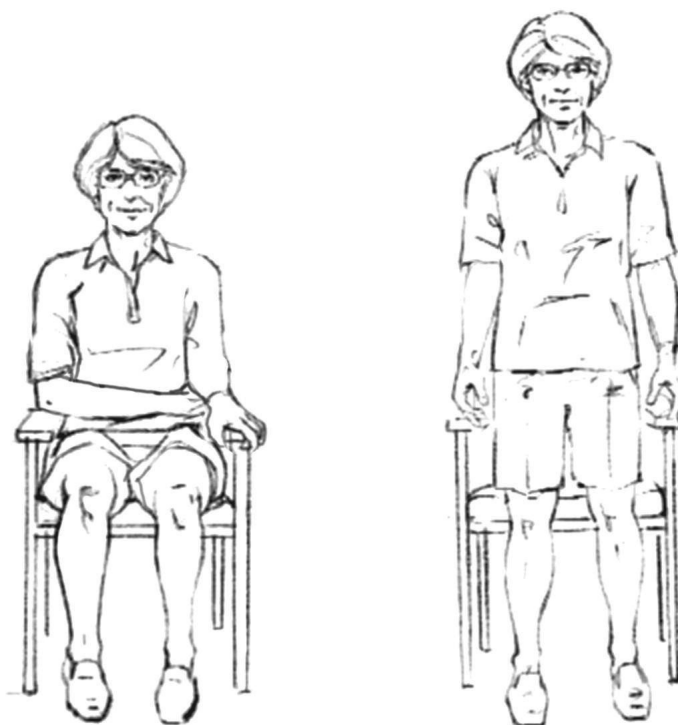

- 
- 1 Gradually increase to 10 times.
  - 2 Stand up slowly using **one hand on arm rest.**
- 

DAILY





## Sit-to-stand

STILL TOO EASY? TRY:



- 
- 1 Stand up slowly with arms crossed in sitting position, keep them crossed when you stand up.
- 

**DAILY**



## Sideways walking

### START WITH:



- 
- 1 Stand up tall and look straight ahead.

---

  - 2 Place your hands on your hips.

---

  - 3 Take a side step to the right with your right leg, then close with left leg so you are standing with your feet shoulder-width apart.

---

  - 4 Repeat this movement to take 10 steps to the right.

---

  - 5 Then take 10 steps to the left in the same way.

---

  - 6 Repeat 10 steps to the right and 10 steps to the left.

---

**DAILY**



## Sideways walking

TOO EASY? THEN TRY:



- 
- 1 Take 10 longer steps to each side.
  - 2 Increase the number of times you take 10 steps to each side, gradually increasing to taking 10 steps to each side 4 times.
- 



## Heel-toe (tandem) standing

### START WITH:

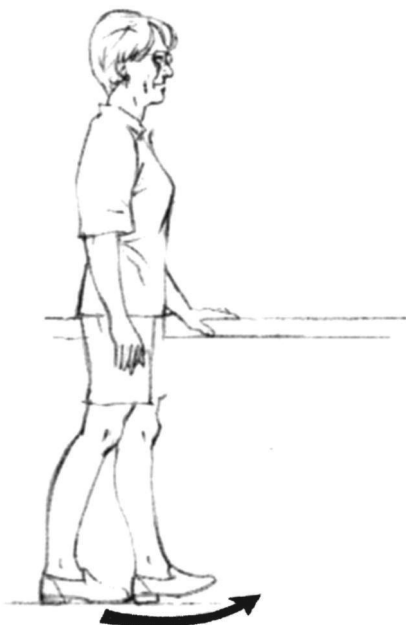

- 1 Stand up tall beside the counter and look straight ahead.
- 2 Hold onto the counter with one hand.
- 3 Place one foot directly in front of the other so the feet form a straight line.
- 4 It is okay to look at your feet to get them lined up, then look ahead for good posture.
- 5 Center your weight between your two feet.
- 6 Hold this standing position for 10 seconds.
- 7 Change the standing position. Take the foot that was behind and place it directly in front of the other foot.
- 8 Hold this position for 10 seconds.

**DAILY**



## Heel-toe (tandem) standing

TOO EASY? THEN TRY:

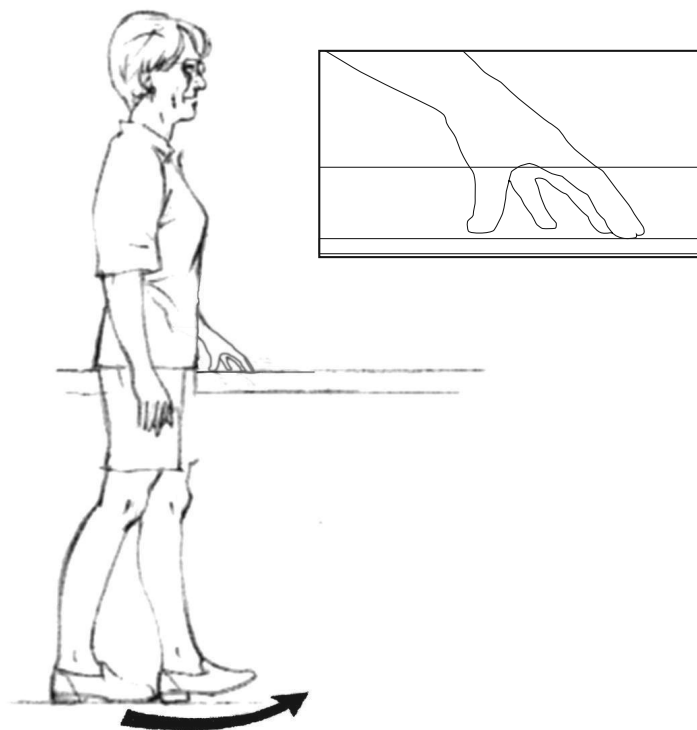

- 
- 1 Stand up tall beside the counter with only your finger tips touching it.
  - 2 Shift weight forward and backward, from foot to foot, while still keeping both feet on the ground.
- 



## Heel-toe (tandem) standing

### STILL TOO EASY? TRY

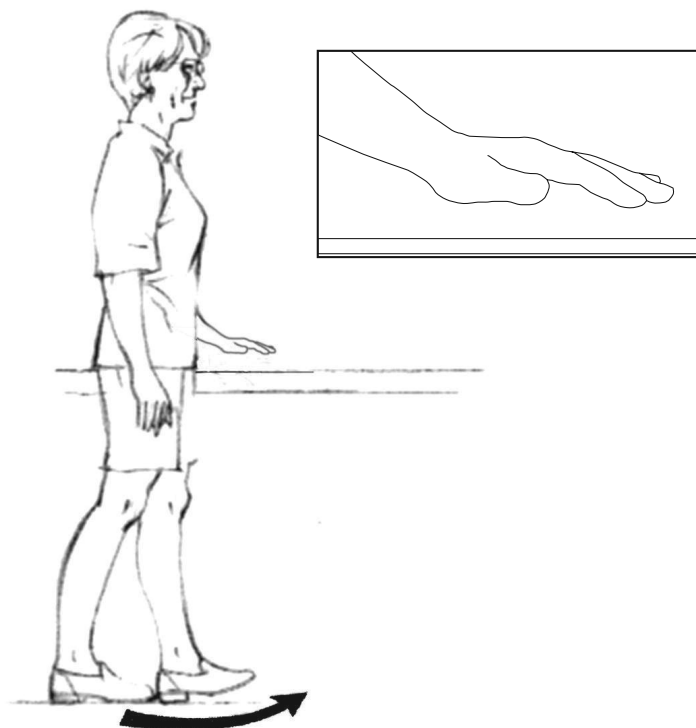

- 1 To advance further, place one hand just above the counter, but not touching.
- 2 You may need to hold onto the counter to get your feet in the correct position and then let go.
- 3 Hold the position for a longer time, gradually increasing to 30 seconds.



## Heel-toe (tandem) walking

START WITH:

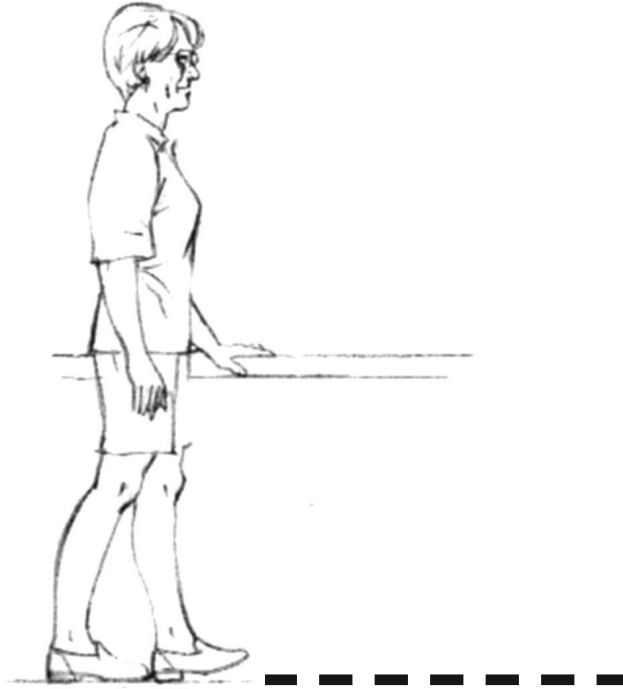

- 
- 1 Stand up tall beside the counter and look straight ahead.
  - 2 Hold onto the counter with one hand.
  - 3 Walk forward by placing one foot directly in front of the other like you're walking on a tightrope. The heel of the front foot should be close to or touching the toes of the back foot.
  - 4 Tandem walk forward for 5-10 steps.
  - 5 Pause, then do another 5-10 steps forward.
- 



## Heel-toe (tandem) walking

### TOO EASY? THEN TRY:

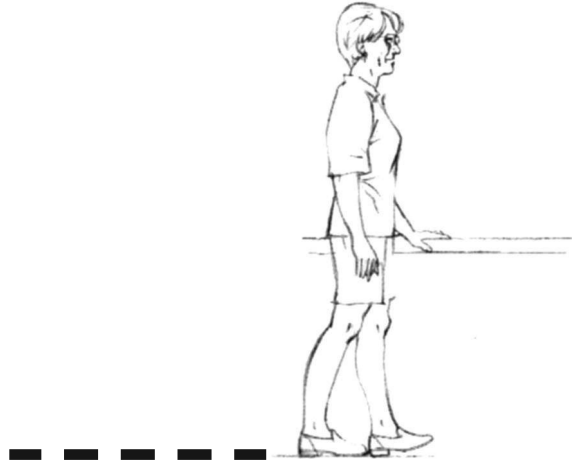

- 1 Include a tandem walk backward with one hand on the counter.

### STILL TOO EASY? THEN TRY:

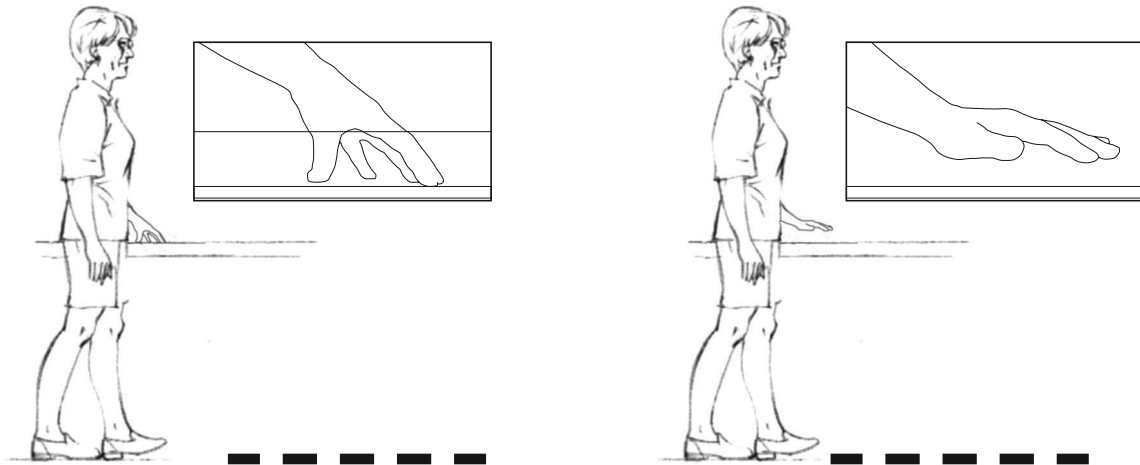

- 1 Try using just fingertips for support with tandem walking forward, then advancing to no support. It's okay to use fingertips or no support only with the forward part of the tandem walk but hold on firmly for the backward part.
- 2 Increase the number of times you walk forward and backward.

**DAILY**





## Strengthening Exercises: DO THESE 3 TIMES A WEEK

1. Side-hip-strengthening exercise
2. Knee-strengthening-exercise
3. Heel raises
4. Toe raises

**Strengthening your muscles is essential** for keeping those bones and muscles healthy that are needed for walking and helping you be independent in your daily activities.

You should **aim to do the strengthening exercises 3 times a week**, with a rest day in between.

Lift the leg slowly through the entire range of movement. Never hold your breath while lifting. Inhale before lifting, exhale while lifting, and inhale again while lowering your leg.



## Side-hip-strengthening exercise

### START WITH:



- 1 Stand up tall with your left side toward the counter.
- 2 Look straight ahead.
- 3 Hold on with your left hand.
- 4 Keep the right leg straight and the foot straight forward.
- 5 Lift the right leg slightly out to the side until your foot is about ONE INCH OFF THE FLOOR.
- 6 Keep back straight. Do not lean forward, backward, or sideways.
- 7 Lower your leg to the floor slowly.
- 8 Repeat 5 times for the right leg.
- 9 Turn around and hold onto the counter with your right hand.
- 10 Repeat this exercise 5 times for the left leg.

**3 TIMES A WEEK**



## Side-hip-strengthening exercise

TOO EASY? THEN TRY:



- 
- 1 Gradually increase to 10 times each leg.
  - 2 Once you are at 10 repetitions, add 2 pounds of ankle weights to each leg.
  - 3 Work up to 10 repetitions using the weight you have added.
  - 4 When 10 repetitions become easy with the current weight, again increase the weight by 1 pound. To progress, repeat this cycle as you get comfortable.
- 



## Front-knee-strengthening exercise

START WITH:

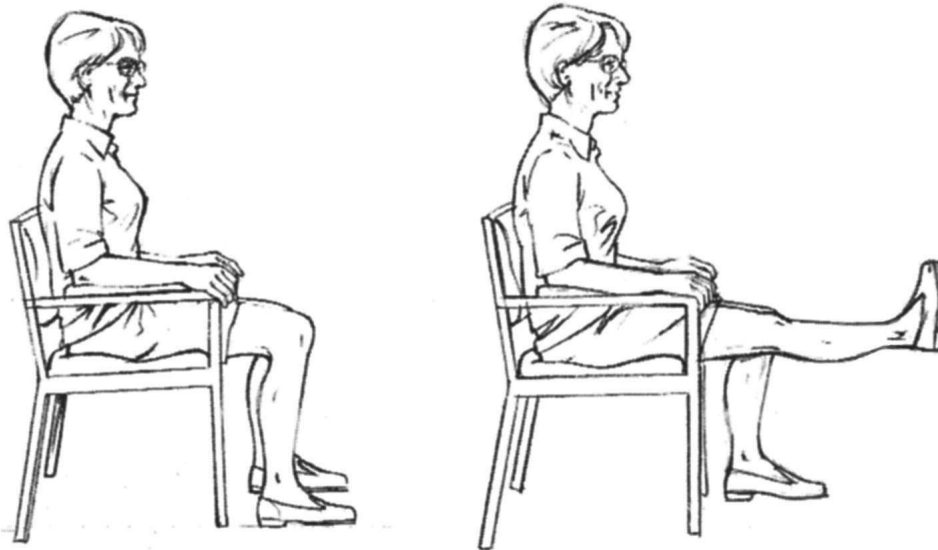

- 1 You can do this exercise while watching TV.
- 2 Sit on a chair with your back well supported.
- 3 Straighten the right leg slowly.
- 4 Hold for 5 seconds.
- 5 Lower the leg slowly.
- 6 Repeat 5 times for the right leg.
- 7 Straighten the left leg slowly.
- 8 Hold for 5 seconds.
- 9 Lower the leg slowly.
- 10 Repeat this exercise 5 times for the left leg.

5 TIMES A WEEK



## Front-knee-strengthening exercise

TOO EASY? THEN TRY:

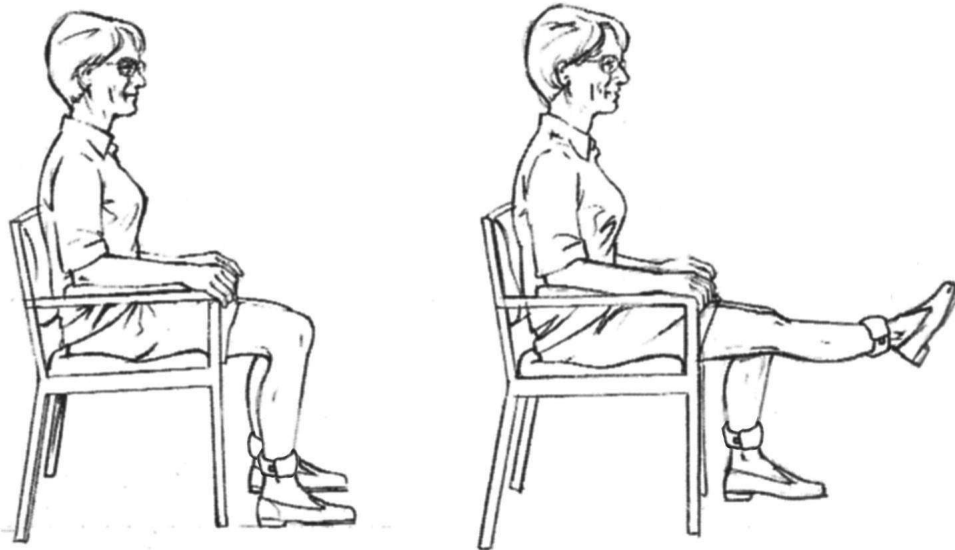

- 1 Gradually increase to 10 times each leg.
- 2 Once you are at 10 repetitions, add 2 pounds of ankle weights to each leg.
- 3 Work up to 10 repetitions using the weight you have added.
- 4 When 10 repetitions become easy with the current weight, again increase the weight by 1 pound. To progress, repeat this cycle as you get comfortable.

5 TIMES A WEEK



## Heel raises

### START WITH:

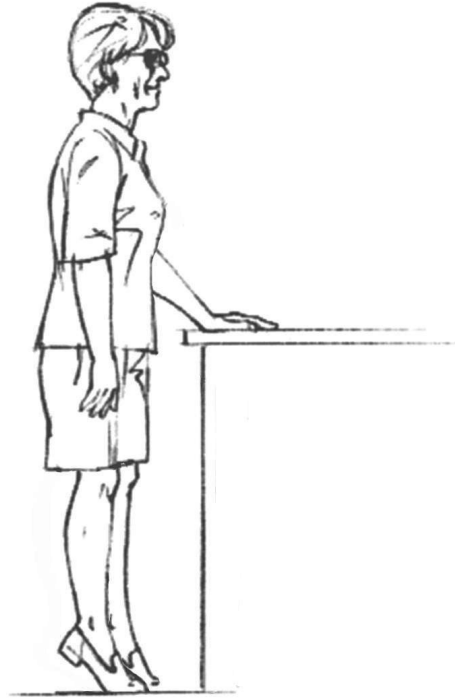

- 1 Stand up tall facing the counter and look straight ahead.
- 2 Hold on with one hand.
- 3 The feet are shoulder-width apart.
- 4 Come up onto your toes without rocking forward.
- 5 Slowly lower the heels to the ground.
- 6 Repeat this exercise 5 times.

5 TIMES A WEEK



## Heel raises

### TOO EASY? THEN TRY:

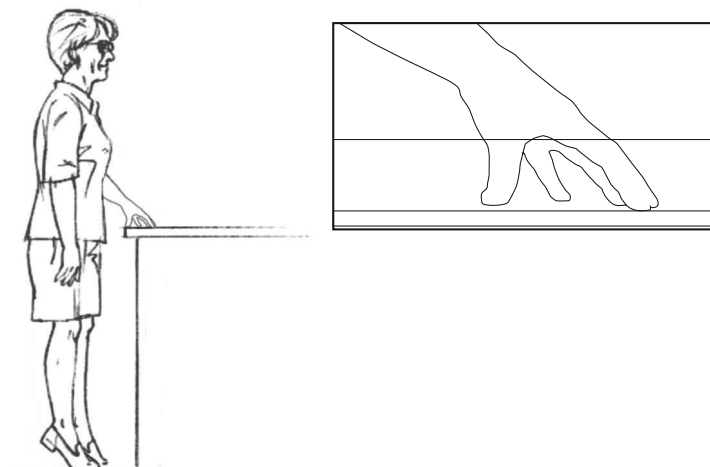

- 1 Gradually increase to 20 times.
- 2 Use just your fingertips touching the counter for support.

### STILL TOO EASY? TRY:

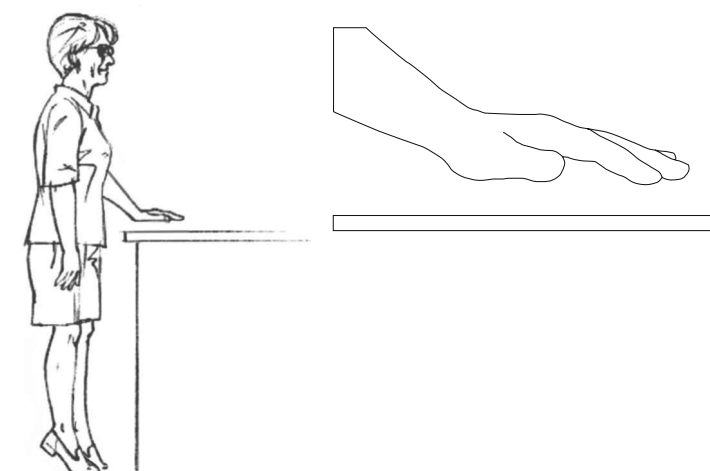

- 1 Then try placing your hand over the counter, but not touching.

5 TIMES A WEEK



## Toe raises

### START WITH:

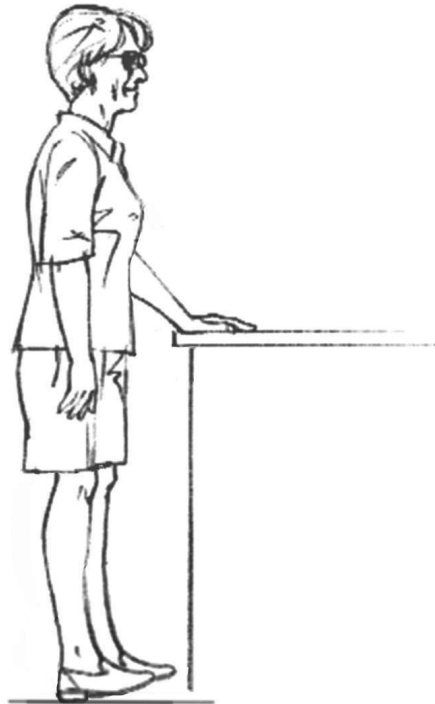

- 
- 1 Stand up tall facing the counter and look straight ahead.
  - 2 Hold on with one hand.
  - 3 Feet are shoulder-width apart.
  - 4 Lift up toes so you come up onto your heels without rocking backward.
  - 5 Slowly lower the toes to the ground.
  - 6 Repeat this exercise 5 times.
- 





## Toe raises

### TOO EASY? THEN TRY:

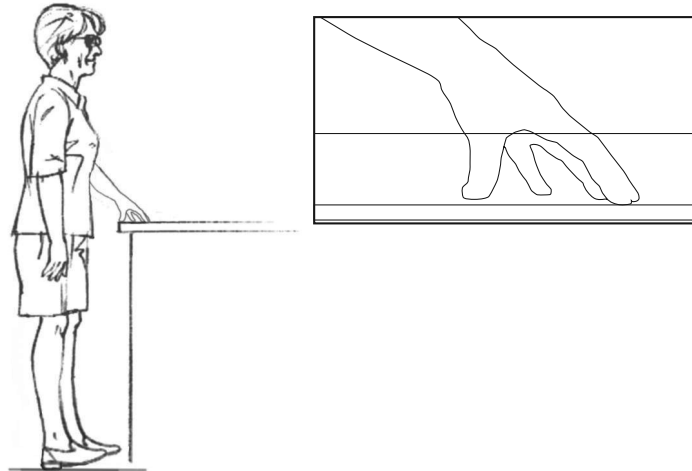

- 1 Gradually increase to 20 times.
- 2 Use just your fingertips touching the counter for support.

### STILL TOO EASY? TRY:

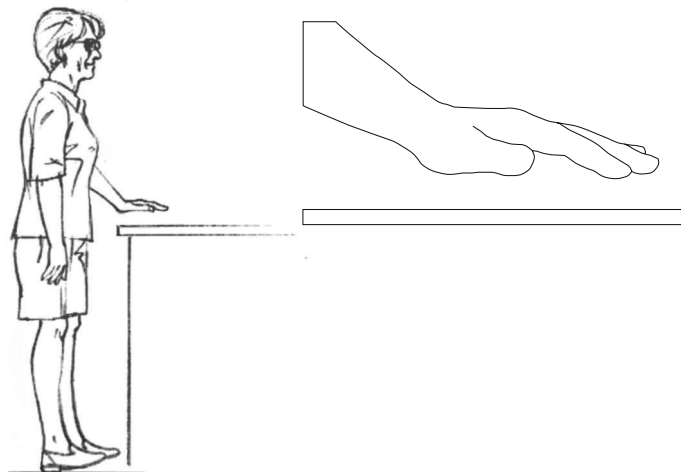

- 1 Place your hand just above the counter, but not touching.

5 TIMES A WEEK



**REMEMBER**

- 
- You need to have good balance and muscle strength to help prevent falls.
- 
- Style points!
    - Use good posture.
    - Don't cheat yourself: use the correct movements for each exercise.
- 
- Breathe!
- 
- Challenge yourself to change!
- 
- With your balance exercises, you can:
    1. Increase the number of times you do each exercise when you are ready.
    2. Decrease the amount you hold on with each exercise.
- 
- With your strength exercises, you can:
    1. Increase the number of times you do each exercise when you are ready.
    2. Increase the weight.
- 
- You need to keep doing the strength exercises at least 3 times a week and the balance exercises daily.
- 
- You can do these exercises all at one time or “snack” on them at different times of the day. Do what works for you.
- 
- Walking is good for you but by itself will not increase or maintain your muscle strength or balance.



# Exercises at a glance

## BALANCE EXERCISES

For more specific instructions on advancing each exercise, refer back to the manual.

### Sit-to-stand

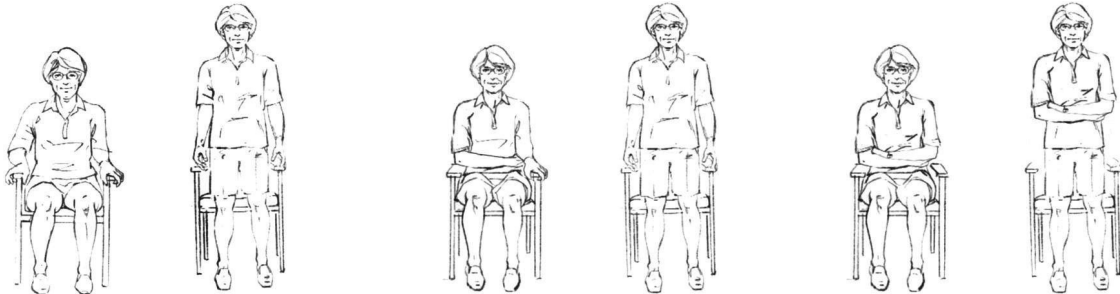

### Sideways walking



### Heel-toe (tandem) standing



### Heel-toe (tandem) walking

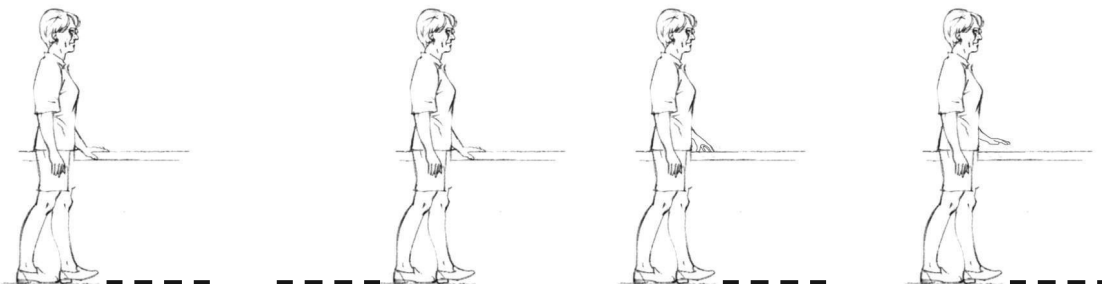

## Strength Exercises

For more specific instructions on advancing each exercise, refer back to the manual.

### Side-hip-strengthening

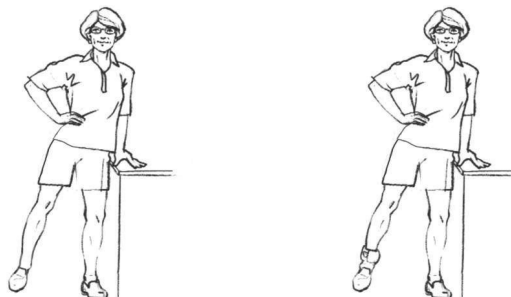

### Front-knee-strengthening

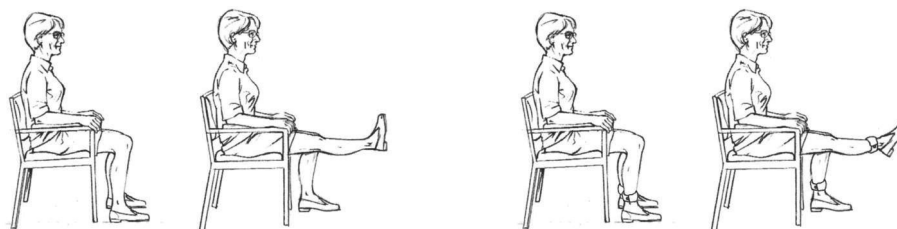

### Heel raises

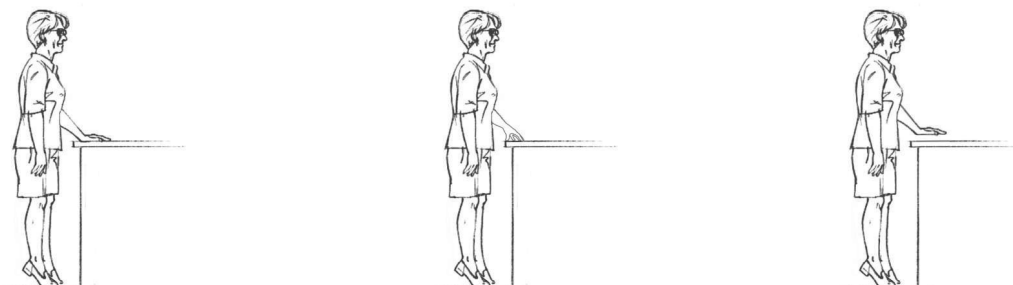

### Toe raises

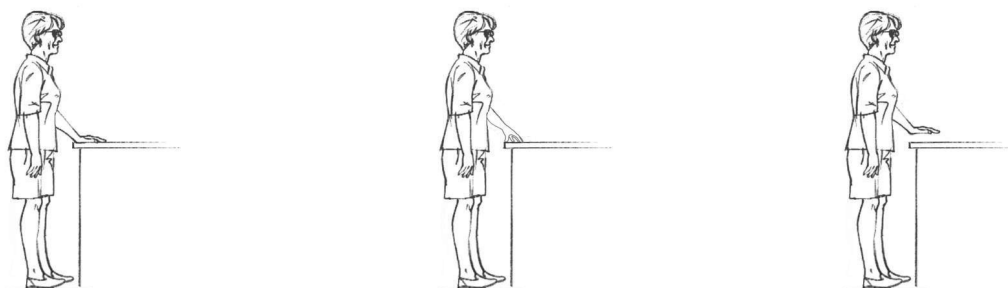

---

---

---

---

---

---

---

---

---

---

---

---

---

---

---

---

---

---

---

---

---

---

---

---

---

---

---

---

---

---



Area with horizontal lines for notes.

